

--	--	--	--	--	--	--	--	--	--

## Fifth Semester B.E. Degree Examination, Dec.2023/Jan.2024 Design of Machine Elements – II

Time: 3 hrs.

Max. Marks: 100

- Note:** 1. Answer any FIVE full questions, choosing ONE full question from each module.  
 2. Missing data if any may suitable assumed.  
 3. Use of design data Hand book is permitted.

### Module-1

- 1 a. A point in a structural member subject to plane stress shown in Fig Q1(a). determine following : i) Normal and Tangential stress on plane MN inclined at an angle of 45 Degree  
 ii) Principal stress and their direction    iii) Maximum shear stress and the direction of the planer on which it occurs.

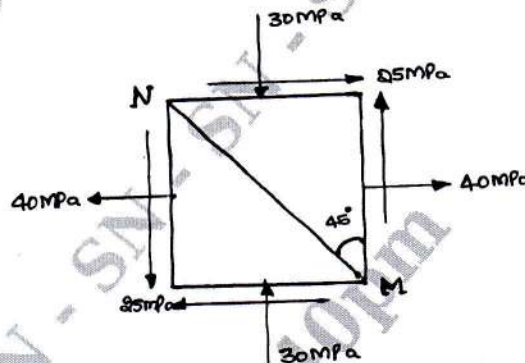

Fig Q1(a)

(10 Marks)

- b. A mild steel shaft of 60mm diameter is subjected to a Bending moment of  $25 \times 10^5 \text{ N-mm}$  and Torque ' $M_t$ '. If the yield point of steel in tension is  $230 \text{ N/mm}^2$ , find the maximum value of this torque without causing yielding of the shaft according to i) Maximum principal stress theory of failure    ii) Maximum shear stress theory of failure. Adopt FOS as 1.5.    (10 Marks)

OR

- 2 a. A mild steel Bracket shown in Fig Q2(a) is subjected to a pull of 10kN. The Bracket has a Rectangular cross section whose depth is twice the width. If the allowable stress for the material is  $80 \text{ N/mm}^2$ , determine cross section of the Bracket.

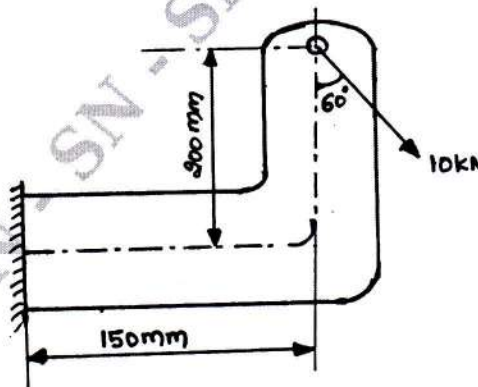

Fig Q2(a)

(10 Marks)

Important Note : 1. On completing your answers, compulsorily draw diagonal cross lines on the remaining blank pages.  
 2. Any revealing of identification, appeal to evaluator and /or equations written eg. 42+8 = 50, will be treated as malpractice.

- b. A circular rod of diameter 50mm is subjected to loads as shown in Fig Q2(b). Determine the Nature and magnitude of stress at the critical points.

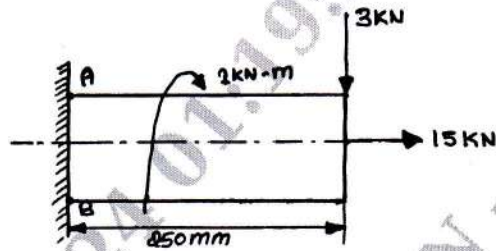

Fig Q2(b)

(10 Marks)

**Module-2**

- 3 a. A notched flat plate shown in Fig Q3(a) is subjected to Bending moment of 10N-m. Determine the maximum stress induced in the member by taking the stress concentration into account.

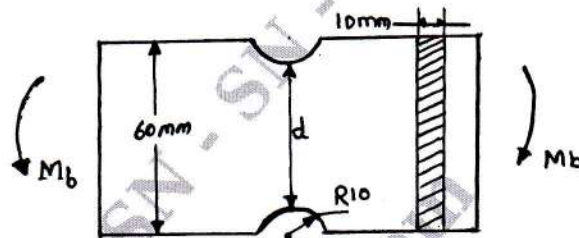

Fig Q3(a)

(10 Marks)

- b. A cantilever beam of width 50mm, depth 150mm is 1.5m long. It is struck by a weight of 1000N that fall from a height of 10mm at its free end. Determine the following :
- Impact factor
  - Instantaneous maximum deflection
  - Instantaneous maximum stress
  - Instantaneous maximum load.

Take  $E = 20.6 \times 10^4 \text{ N/mm}^2$ .

(10 Marks)

**OR**

- 4 a. Explain the factors which effect the Endurance limit. (10 Marks)
- b. A steel rod which is oil Quenched (SAE 9260)  $\sigma_{ut} = 1089.5\text{MPa}$ ,  $\sigma_{yt} = 689.4\text{MPa}$ ,  $\sigma_{-1} = 427.6\text{MPa}$ , is subjected to a tensile load which varies from 120kN to 40kN. Design the safe diameter of the rod using "Soderberg Diagram". Adopt factor of safety as 2, stress concentration factor as unity and correction factor for load, size and surface as 0.75, 0.85 and 0.91 respectively. (10 Marks)

**Module-3**

- 5 a. A flange coupling is used to connect two co-axial shaft of diameter 80mm to transmit 60kW at 200rpm, Total six M14  $\times$  1.5mm bolts are used on a bolt circle diameter of 240mm. The hub diameter is 150mm and flange thickness is 20mm. Determine :
- The shear stress induced in shaft
  - The shear stress induced in bolts
  - The shear stress induced in key by taking  $\sigma_c = 80\text{MPa}$
  - The shear stress induced in flanges.

(10 Marks)

- b. A rectangular sunk key 14mm wide, 10mm thick and 75mm long is required to transmit 1200 N-m torque for a 50mm diameter solid shaft. Determine whether the length is sufficient or not, for the permissible shear stress and crushing stress are limited to 56MPa and 168MPa respectively. (10 Marks)

OR

- 6 A horizontal piece of commercial shafting supported by two bearings 1.5m apart. A keyed gear 20° involute and 175mm in diameter is located 400mm to the left of the Right bearing and is driven by a gear directly behind it. A 600mm diameter pulley is keyed to the shaft 600mm to the right of the left bearing and drives a pulley with a horizontal belt directly behind it. The tension ratio of the belt is 3 to 1, with the slack side on top. The drive transmits 45kW at 330rpm. Take  $K_b = K_t = 1.5$ . Calculate the necessary diameter of the shaft and angular deflections in degrees. Use allowable shear stress 40Mpa and  $G = 80 \times 10^9 \text{ N/mm}^2$ . (20 Marks)

**Module-4**

- 7 a. List advantage and disadvantages of Riveted Joint over Welded Joint. (10 Marks)  
 b. A double riveted lap Joint is to be made between 9mm plates. If the safe working stress in tension, crushing and shear are  $80\text{N/mm}^2$ ,  $120\text{N/mm}^2$  and  $60\text{N/mm}^2$  respectively, design the riveted Joint. (10 Marks)

OR

- 8 a. A plate of 50mm wide and 10mm thick is to be welded to another plate by means of transverse fillet weld at the ends. If the allowable tensile stress is  $100\text{N/mm}^2$ , determine the length of weld. (10 Marks)  
 b. A solid circular shaft 25mm in diameter is welded to a support by means of a fillet weld as shown in Fig Q8(b). Determine the leg dimensions of the weld if the permissible shear stress is  $95\text{N/mm}^2$

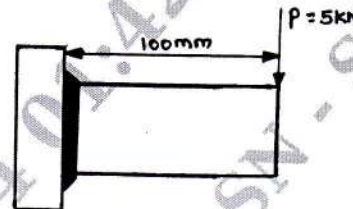

Fig Q8(b)

(10 Marks)

**Module-5**

- 9 a. The structural connection shown in Fig. Q9(a) subjected to an eccentric load of 10kN. All bolts are identical and having shear strength of 80MPa.

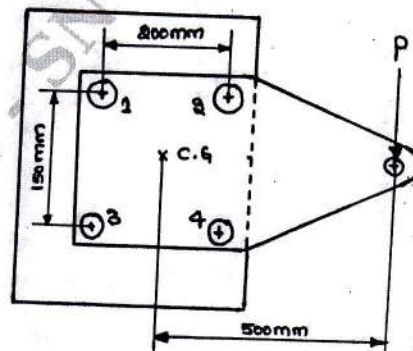

Fig Q9(a)

(10 Marks)

- b. A bracket shown in Fig Q9(b) carries a load of 50kN. Determine the size of bolt, if the permissible tensile stress in the bolt material is 200MPa.

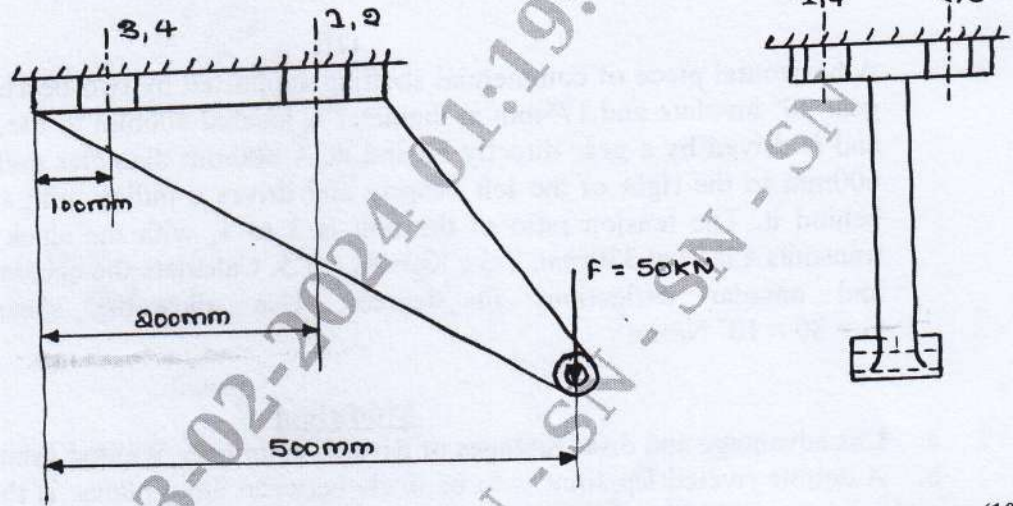

Fig Q9(b)

(10 Marks)

OR

- 10 a. The cylinder head of a steam engine is held in position by 10 Bolts. The diameter of cylinder is 400mm and the maximum pressure of steam is 1MPa. A copper gasket is used to make the joint leak proof. Determine the standard size of bolts required by taking the design tensile stress for bolt materials is 90MPa. (10 Marks)
- b. Derive an expression for torque required to raise the load on square threaded screw. (10 Marks)

\*\*\*\*\*